

RESATEC® KETTINGSPANNERS "TEKS"

RESATEC® CHAIN TENSIONERS "TEKS"

Simplex, duplex & triplex - ISO 9001



Materiaal

Kettingwiel: staal C45

Lager: chroomstaal, dicht

Bout en moer: gegalvaniseerd

Behuizing en arm: staal



Simplex							
Type	Steek	Code	ISO	Tanden	A	B	Kg.
TEKS 3	3/8" x 7/32"	6020110330	06B1	15	20 ÷ 50	M10	0,60
TEKS 3	1/2" x 5/16"	6020110340	08B1	15	20 ÷ 50	M10	0,65
TEKS 5	5/8" x 3/8"	6020110350	10B1	15	26 ÷ 67	M12	2,32
TEKS 5	3/4" x 7/16"	6020110360	12B1	15	26 ÷ 67	M12	2,55
TEKS 6	1" x 17,02	6020110380	16B1	13	37 ÷ 102	M20	5,00
TEKS 7	1"1/4 x 3/4"	6020110400	20B1	13	39 ÷ 122	M20	8,55
TEKS 7	1"1/2 x 1"	6020110420	24B1	11	39 ÷ 142	M20	8,90

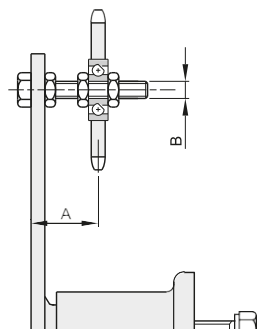

Materiaal

Kettingwiel: staal C45

Lager: chroomstaal, dicht

Bout en moer: gegalvaniseerd

Behuizing en arm: staal



Duplex							
Type	Steek	Code	ISO	Tanden	A	B	Kg.
TEKS 3	3/8" x 7/32"	6020120330	06B2	15	25 ÷ 44	M10	0,65
TEKS 4	1/2" x 5/16"	6020120340	08B2	15	27 ÷ 43	M10	1,15
TEKS 5	5/8" x 3/8"	6020120350	10B2	15	34 ÷ 59	M12	2,55
TEKS 5	3/4" x 7/16"	6020120360	12B2	15	36 ÷ 57	M12	3,00
TEKS 6	1" x 17,02	6020120380	16B2	13	52 ÷ 86	M20	5,80
TEKS 7	1"1/4 x 3/4"	6020120400	20B2	13	57 ÷ 104	M20	10,10
TEKS 7	1"1/2 x 1"	6020120420	24B2	11	63 ÷ 118	M20	10,75

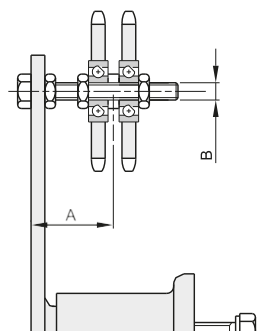

Materiaal

Kettingwiel: staal C45

Lager: chroomstaal, dicht

Bout en moer: gegalvaniseerd

Behuizing en arm: staal



Triplex							
Type	Steek	Code	ISO	Tanden	A	B	Kg.
TEKS 4	3/8" x 7/32"	6020130330	06B3	15	31 ÷ 39	M10	0,95
TEKS 5	1/2" x 5/16"	6020130340	08B3	15	40 ÷ 53	M12	2,45
TEKS 6	5/8" x 3/8"	6020130350	10B3	15	53 ÷ 85	M20	4,95
TEKS 6	3/4" x 7/16"	6020130360	12B3	15	56 ÷ 83	M20	5,20
TEKS 7	1" x 17,02	6020130380	16B3	13	70 ÷ 70	M20	9,40
TEKS 7	1"1/4 x 3/4"	6020130400	20B3	13	75 ÷ 86	M20	11,70
TEKS 7	1"1/2 x 1"	6020130420	24B3	11	87 ÷ 94	M20	12,70

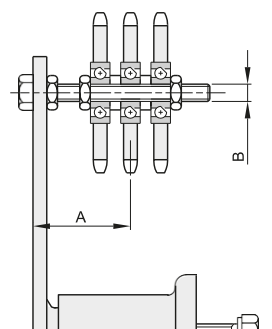

RESATEC® KETTINGSPANNERS "TECRS" RESATEC® CHAIN TENSIONERS "TECRS"

Simplex, duplex - ISO 9001



Materiaal

Spanner: kunststof

Bout en moer: gegalvaniseerd

Behuizing en arm: staal



Simplex						
Type	Steek	Code	ISO	A	B	Kg.
TECRS 2	3/8" x 7/32"	6020210330	06B1	18 ÷ 35	M8	0,30
TECRS 3	1/2" x 5/16"	6020210340	08B1	23 ÷ 45	M10	0,56
TECRS 4	5/8" x 3/8"	6020210350	10B1	24 ÷ 44	M10	0,82
TECRS 5	3/4" x 7/16"	6020210360	12B1	30 ÷ 60	M12	2,17

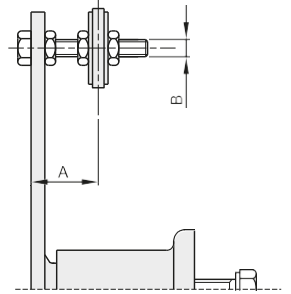

Materiaal

Spanner: kunststof

Bout en moer: gegalvaniseerd

Behuizing en arm: staal



Duplex						
Type	Steek	Code	ISO	A	B	Kg.
TECRS 2	3/8" x 7/32"	6020220330	06B2	25 ÷ 30	M8	0,32
TECRS 3	1/2" x 5/16"	6020220340	08B2	30 ÷ 34	M10	0,60
TECRS 4	5/8" x 3/8"	6020220350	10B2	34 ÷ 46	M10	0,90
TECRS 5	3/4" x 7/16"	6020220360	12B2	40 ÷ 52	M12	2,31

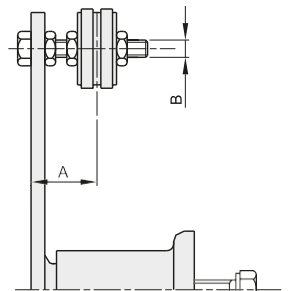

RESATEC® RIEMSPANNERS "TERE" RESATEC® BELT TENSIONERS "TERE"

ISO 9001



Materiaal

Rol: kunststof

Lager: chroomstaal, dicht

Bout en moer: gegalvaniseerd

Behuizing en arm: staal



Type	Code	A	B	C	Ø D	E	Kg.
TERE 2	6020300301	61	43	80	30	35	0,32
TERE 3	6020300401	70	56	100	40	45	0,62
TERE 4	6020300402	88	57	100	40	45	0,85
TERE 5	6020300601	122	76	130	60	60	2,34
TERE 6	6020300801	158	109	175	80	90	4,90
TERE 7	6020300802	211	154	220	80	135	8,20

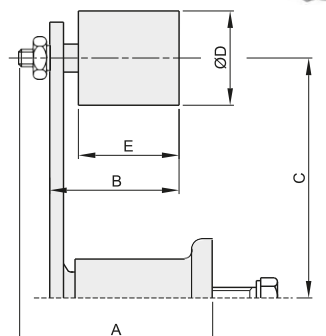

KETTINGSPANWIELEN MET KOGELLAGER

CHAIN-STRETCHER SPROCKETS WITH BALL BEARING

DIN 8187 - ISO 606

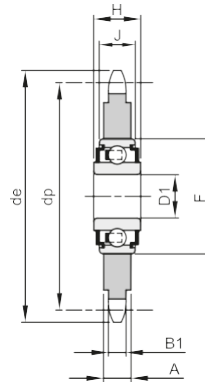
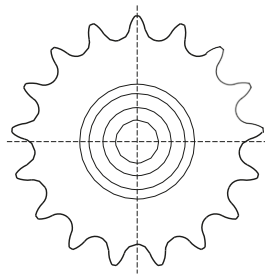

Materiaal: staal C45



Z	Code	Steek	Iso	De	Dp	B1	A	D1	F	H	J	Kg.
23	364308023	8 x 1/8"	05B-1	62,2	58,75	2,8	7,0	16 ^{+0,26} _{+0,13}	40	18,3	12	0,13
21	364330021	3/8" x 7/32"	06B-1	67,6	63,91	5,3	5,3	16 ^{+0,26} _{+0,13}	40	18,3	12	0,15
22	364330022	3/8" x 7/32"	06B-1	70,6	66,93	5,3	5,3	16 ^{+0,26} _{+0,13}	40	18,3	12	0,16
18	364341018	1/2" x 1/8"	081-1	79,4	73,14	3,0	7,0	16 ^{+0,26} _{+0,13}	40	18,3	12	0,18
15	364342015	1/2" x 3/16"	083-1	67,4	61,09	4,5	7,0	16 ^{+0,26} _{+0,13}	40	18,3	12	0,16
16	364342016	1/2" x 3/16"	083-1	71,4	65,10	4,5	7,0	16 ^{+0,26} _{+0,13}	40	18,3	12	0,17
18	364342018	1/2" x 3/16"	083-1	79,4	73,14	4,5	7,0	16 ^{+0,26} _{+0,13}	40	18,3	12	0,20
14	364340014	1/2" x 5/16"	08B-1	61,9	57,07	7,2	7,2	16 ^{+0,26} _{+0,13}	40	18,3	12	0,13
16	364340016	1/2" x 5/16"	08B-1	69,9	65,10	7,2	7,2	16 ^{+0,26} _{+0,13}	40	18,3	12	0,17
18	364340018	1/2" x 5/16"	08B-1	78,0	73,14	7,2	7,2	16 ^{+0,26} _{+0,13}	40	18,3	12	0,22
14	364350014	5/8" x 3/8"	10B-1	78,2	71,34	9,1	9,1	16 ^{+0,26} _{+0,13}	40	18,3	12	0,23
15	364350015	5/8" x 3/8"	10B-1	83,2	76,36	9,1	9,1	16 ^{+0,26} _{+0,13}	40	18,3	12	0,27
17	364350017	5/8" x 3/8"	10B-1	93,3	86,39	9,1	9,1	16 ^{+0,26} _{+0,13}	40	18,3	12	0,36
13	364360013	3/4" x 7/16"	12B-1	87,8	79,59	11,1	11,1	16 ^{+0,26} _{+0,13}	40	18,3	12	0,34
15	364360015	3/4" x 7/16"	12B-1	99,8	91,63	11,1	11,1	16 ^{+0,26} _{+0,13}	40	18,3	12	0,47
12	364380012	1" x 17,02	16B-1	109,7	98,14	16,2	16,2	20 ^{+0,10} ₋₀	47	17,7	14	0,72
13	364400013	1" 1/4 x 3/4"	20B-1	147,7	132,67	18,5	18,5	25 ^{+0,10} ₋₀	52	21,0	15	1,64

RESATEC® SPANELEMENTEN "TE" RESATEC® TENSIONER ELEMENTS "TE"

ISO 9001

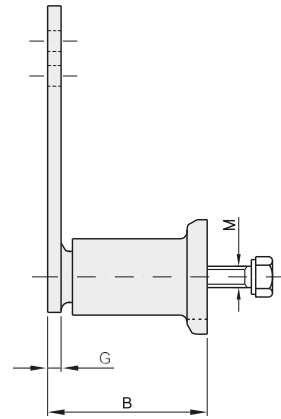
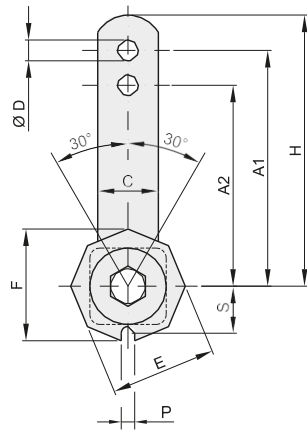

Materiaal

Behuizing: staal / RVS

Arm: staal / RVS

Schroef: gegalvaniseerd / RVS



Type	Code	A1	A2	B	C	Ø D	E	F	G	H	maximale kracht (N)		M	P	S	Kg.
											Kracht (N) Δ 0 - 32° A1	A2				
TE 2	6021000020	80	60	52	20	8,5	35	38	5	90	0 - 90	0 - 110	M 6	8	16,5	0,25
TE 3	6021000030	100	80	63	25	10,5	46	48	5	115	0 - 140	0 - 170	M 8	8,5	19,5	0,45
TE 4	6021000040	100	80	78	30	10,5	56	60	6	115	0 - 320	0 - 430	M10	8,5	24,5	0,68
TE 5	6021000050	130	100	108	50	12,5	72	78	8	155	0 - 820	0 - 1050	M12	10,5	34	1,70
TE 6	6021000060	175	140	145	60	20,5	93	100	10	205	0 - 1500	0 - 1880	M16	12,5	42	3,70
TE 7	6021000070	220	175	198	70	20,5	106	114	12	255	0 - 2500	0 - 3200	M20	12,5	50	6,50
TE 2 - SS	6021000120	80	60	52	20	8,5	35	38	5	90	0 - 90	0 - 110	M 6	8	16,5	0,25
TE 3 - SS	6021000130	100	80	63	25	10,5	46	48	5	115	0 - 140	0 - 170	M 8	8,5	19,5	0,45
TE 4 - SS	6021000140	100	80	78	30	10,5	56	60	6	115	0 - 320	0 - 430	M10	8,5	24,5	0,68
TE 5 - SS	6021000150	130	100	108	50	12,5	72	78	8	155	0 - 820	0 - 1050	M12	10,5	34	1,70

RESATEC® KETTINGSPANELEMENTEN "CRS" RESATEC® CHAIN TENSIONER ELEMENTS "CRS"

Simplex & duplex - ISO 9001

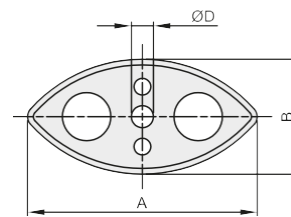
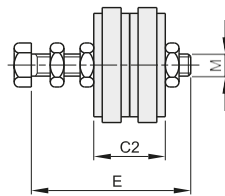
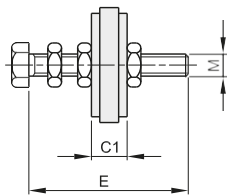

Materiaal

Spanner: kunststof

Bout en moer: gegalvaniseerd



Type	Steek	Code	ISO	A	B	C1	C2	Ø D	M	E	Simplex Kg.	Duplex Kg.
CRS 3/8"	3/8" x 7/32"	6023330000	06B	74	40	10,2	20,4	8	M8	45	0,05	0,07
CRS 1/2"	1/2" x 5/16"	6023340000	08B	96	50	13,9	27,8	10	M10	60	0,11	0,15
CRS 5/8"	5/8" x 3/8"	6023350000	10B	125	55	16,5	33	10	M10	60	0,14	0,22
CRS 3/4"	3/4" x 7/16"	6023360000	12B	147	80	19,5	39	12	M12	80	0,22	0,36

RESATEC® KETTINGWIELEN "KS" RESATEC® SPROCKET WHEELS "KS"

DIN 8187 - ISO 9001

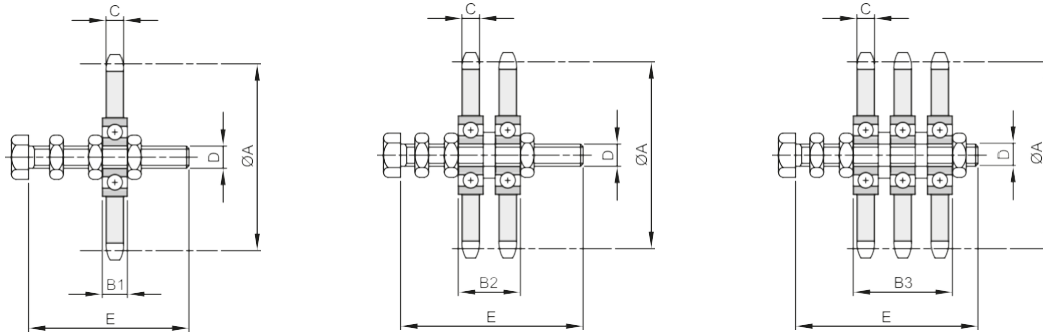

Materiaal

Kettingwiel: staal C45

Lager: chroomstaal, dicht

Bout en moer: gegalvaniseerd



Type	Code	ISO	Tanden	Ø A	B1	B2	B3	C	D	E	Simplex Kg.	Duplex Kg.	Triplex Kg.
KS 3/8" x	6022330151	06B-1-2-3	15	45,81	9	19,2	29,4	5,7	M10	60	0,15	0,20	0,25
KS 1/2" x	6022340151	08B-1-2	15	61,08	9	22,9		7,2	M10	60	0,20	0,35	
KS 1/2" x	6022340152	08B-1-2-3	15	61,08	12	26,0	40,0	7,2	M12	80	0,23	0,45	0,50
KS 5/8" x 3/8"	6022350151	10B-1-2-3	15	76,36	12	28,6	45,2	9,1	M12	80	0,37	0,60	0,95
KS 5/8" x 3/8"	6022350152	10B-1-2-3	15	76,36	15	31,5	48,2	9,1	M20	120	0,70	1,00	1,25
KS 3/4" x	6022360151	12B-1-2	15	91,63	12	31,5		11,5	M12	80	0,60	1,05	
KS 3/4" x	6022360152	12B-1-2-3	15	91,63	15	34,5	54,0	11,5	M20	120	0,90	1,35	1,50
KS 1" x	6022380131	16B-1-2-3	13	106,14	15	46,9	78,8	16,2	M20	120	1,30	2,10	2,90
KS 1 1/4" x 3/4"	6022400131	20B-1-2-3	13	132,67	15	51,5	88,0	18,5	M20	140	2,05	3,60	5,20
KS 1 1/2" x 1"	6022420111	24B-1-2-3	11	135,23	15	63,4	111,8	24,1	M20	160	2,40	4,25	6,20

RESATEC® RIEMSPANELEMENTEN "RE" RESATEC® BELT ROLLER ELEMENTS "RE"

DIN 8187 - ISO 9001

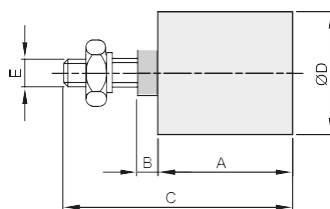

Materiaal

Rol: kunststof

Lager: chroomstaal, dicht

Bout en moer: gegalvaniseerd



Type	Code	A	B	C	Ø D	E	Kg.
RE 2	6023000301	35	3	51	30	M8	0,07
RE 3	6023000401	45	6	67	40	M10	0,17
RE 4	6023000401	45	6	67	40	M10	0,17
RE 5	6023000601	60	7,5	89	60	M12	0,39
RE 6	6023000801	90	9	127	80	M20	1,20
RE 7	6023000802	135	7	167	80	M20	1,70