

VIERPUNTS FLENSLAGERBLOKKEN PTI

FOUR BOLT FLANGE UNITS PTI

Gegoten lagerblokken / FWS 20 KG RCJA20 - FWS 50 KG RCJA50



FWS KG RCJA

Trekbus (inbegrepen)

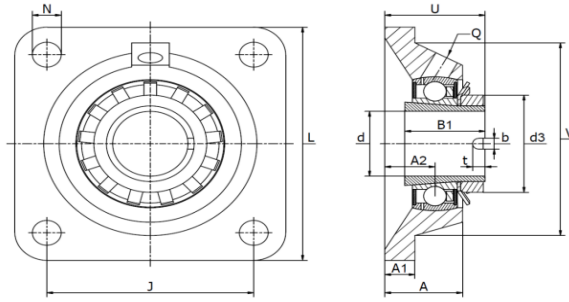

Materiaal: gietijzeren behuizing, radiale insert kogellager

Type	Code	Afmetingen (mm)														(kg)			
		d	L	U	A	A ₁	A ₂	B ₁	d _{3 max}	b	t	J	N	Q	V	Lagertype + trekbus	Huis	Gewicht	Kap
FWS 20 KG - RCJA20	310050204	20	86	42,5	29,0	10,0	19	28	32	5	5	63,5	11,5	1/8"	68	GSH 20 RRB	CJ04	0,60	-
FWS 25 KG - RCJA25	310050205	25	95	42,5	29,0	11,0	19	28	38	5	5	70,0	11,5	1/8"	74	GSH 25 RRB	CJ05	0,76	KASK05
FWS 30 KG - RCJA30	310050206	30	108	46,8	29,0	12,0	20	32	45	5	5	82,5	11,5	1/8"	85	GSH 30 RRB	CJ06	1,11	KASK06
FWS 35 KG - RCJA35	310050207	35	118	50,5	30,5	12,5	21	34	52	5	5	92,0	14,0	1/8"	100	GSH 35 RRB	CJ07	1,46	KASK07
FWS 40 KG - RCJA40	310050208	40	130	56,8	34,5	13,0	24	38	58	5	5	101,5	14,0	1/8"	110	GSH 40 RRB	CJ08	1,89	KASK08
FWS 45 KG - RCJA45	310050209	45	137	56,7	35,0	13,0	24	46	62	5	5	105,0	14,0	1/8"	116	GSH 45 RRB	CJ09	2,22	Kap Ø40/45
FWS 50 KG - RCJA50	310050210	50	143	60,8	39,0	13,0	28	40	70	5	5	111,0	18,0	1/8"	125	GSH 50 RRB	CJ10	2,30	KASK10